



RTG Electrification



Making ports more sustainable with E-RTGs

AS NATIONAL AND INTERNATIONAL LEGISLATIVE REQUIREMENTS ON ENVIRONMENTAL STANDARDS IN PORTS CONTINUE TO BE TIGHTENED, THE INDUSTRY HAS BEEN INTENSIFYING EFFORTS TO OPERATE MORE EFFICIENTLY AND MORE SUSTAINABLY.

GIVEN THE INTEGRAL ROLE RTGS PLAY IN PORT OPERATIONS, REPLACING DIESEL WITH ELECTRICAL POWER TO OPERATE THESE CRANES CAN BE AN IMPORTANT ELEMENT IN IMPROVING OPERATIONAL AND ENVIRONMENTAL PERFORMANCE. INTEREST IN THE ELECTRIFICATION OF RTGS HAS BEEN GROWING FOR SEVERAL YEARS; A TREND THAT IS GAINING RENEWED MOMENTUM ONCE AGAIN.



Electrifying RTGs:

- Reduces CO₂ and NOX emissions
- Reduces noise pollution
- Reduces maintenance costs and downtime
- Reduces fuel costs

Cavotec designs and manufactures solutions for the electrification of RTGs which fall into two main categories:

- RTG cable reel electrical power supply in low and medium voltages (LV, MV)
- RTG conductor bar electrical power supply in LV

Working closely with customers, Cavotec engineers provide support throughout the entire lifetime of a product including:

- Feasibility analysis
- Quayside operations
- Feeding points
- Cable protection
- RTG side movement
- Plug/unplug
- Safety
- Traffic crossings

Cable reel technology

ELECTRIFYING CRANES HAS ALWAYS BEEN PART OF THE PORT STRATEGY WHEN LOOKING UPON OPERATION EFFICIENCY AND EMISSION REDUCTIONS. THE ELECTRIFICATION WITH THE CABLE REEL TECHNOLOGY HAS BEEN ADOPTED BY MANY PORTS AND SINCE THEN HAS DEMONSTRATED TO BE A PROVEN AND HIGHLY RELIABLE TECHNOLOGY. WOULD IT BE FOR RETROFITTING EXISTING DIESEL RTGS OR POWERING BRAND NEW RTGS, THE CABLE REEL SOLUTION REPRESENTS STRONG BENEFITS FOR PORTS.



BENEFITS OF USING CABLE REELS

Customers around the world have seen the following benefits of cable reel technology:

- High degree of flexibility with a logical, user-friendly interface
- Minimal infrastructure investment required
- In the unlikely event of technical failure, downtime is kept to a minimum
- Low maintenance costs
- Manual connection and disconnection
- The system can be adapted to MV power supply
- Cost efficiency
- Unrivalled safety for all types of electrical connection

Port authorities and crane manufacturers have used cable reel technology to operate STS and RMG cranes for many years. Operators know how to operate and maintain it, thus making the electrification of existing RTGs a natural, incremental step.





ENGINEERING AND DESIGNING AN EFFICIENT E-RTG SYSTEM WITH CABLE REELS

When electrifying RTGs, a location for the power Feeding Point needs to be identified. Two options are available depending on the use of the RTG and how RTG operations are conducted:

End Feed Point (EFP)

- Feeding point of the RTG is located at the end location of the container block
- RTG moves in one direction from the feed point
- RTG working one block but will require more cables

Centre Feed Point (CFP)

- Feed point of the RTG is located in the centre
- RTG moves in both directions from the feeding point
- RTG working more than one container block without being unplugged (less cable)

In order to improve operational efficiency, and to reduce connection and disconnection times, Cavotec has developed the Double Anchor Openable system (DACO) that enables easy connection and disconnection to and from the E-RTG.

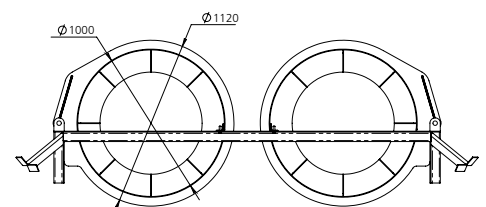
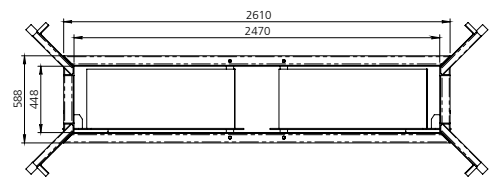



ADAPTIVE CABLE GUIDE FOR RTG ELECTRIFICATION

Cable guiding

In order to improve operational efficiency and to ensure ease of connection and disconnection to and from the E-RTG, Cavotec has developed a self-adjusting cable guide that follows the cable channel where power cables run, thus ensuring optimal crane positioning.

Our system is equipped with ultrasonic sensors linked to the crane PLC that enables positioning detection making operations safer and quicker.

The cable guide adjustment range is typically +/- 250mm

- Cables must be laid in the cable trench or channel accurately
- Adaptive cable guide, in case of cable trench installation, is able to compensate sideways
- Cavotec has developed a self adjusting cable guide that follows the channel
- Cable guide adjustment range +/- 250mm
- Ultrasonic sensors linked to crane PLC perform position detection and channel alignment

LV Switching panel

- Cavotec engineers LV switching panels which are used between the power grid and the gen-set
- Based on client request, Cavotec can customize them in order to meet our client requirements

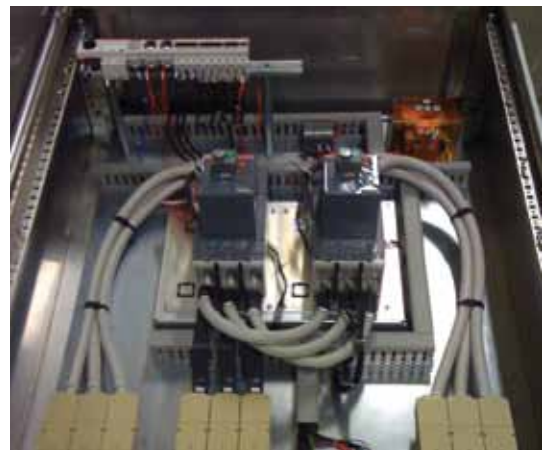
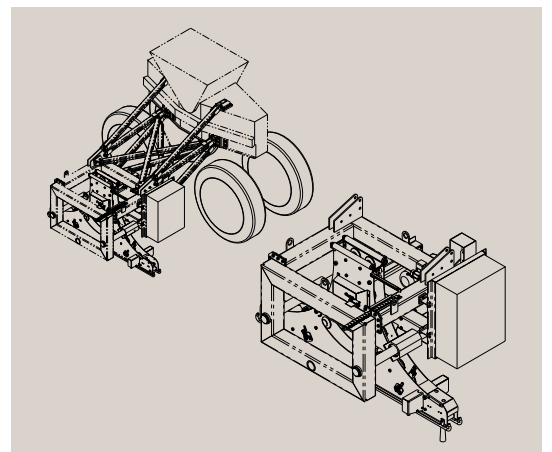



ADVANCED ELECTRICAL JUNCTION BOXES, PLUGS AND SOCKETS AS KEY ELEMENTS OF E-RTGS

Cavotec's expertise of the electrification of mobile equipment supports applications that operate in the most demanding of environments. Our experience enables our customers to develop complete electrical connection systems that include:

Yard junction boxes:

Having a safe and robust junction box is a key element of the E-RTG system. Cavotec manufactures a wide range of junction boxes to guarantee safe operation and low maintenance costs.

- Standard LV and MV junction boxes
- Includes: contactor/circuit breaker, mechanical interlock, pilot lights, emergency stop
- Due to the specific location of some projects and based on our strong willingness to support each customer request, Cavotec is also able to customise LV and MV junction boxes upon request.

Power Connectors:

Cavotec connectors are manufactured according to the highest industry standards and allow our customers to quickly connect and disconnect equipment from power cables. Our Push-pull System is widely regarded as one of the most efficient and safest ways for powering heavy mobile equipment.

- Cavotec connectors are available either as LV (up to 1.000V-660Amp), or MV (up to 15.000V-500Amp)
- Push-pull System for easy and quick connection and disconnection
- IP 66
- Pilot pins for control circuit

Special versions can be provided with:

- Higher amperage
- Available mechanical interlock
- Available FO connectors





Conductor Bar Solutions

AS INTEREST IN USING CONDUCTOR RAILS INSTEAD OF DIESEL GENERATORS TO POWER RTG GROWS THROUGHOUT THE GLOBAL PORTS INDUSTRY, CAVOTEC CONTINUES TO DEVELOP AND AUTOMATE CONDUCTOR RAIL TECHNOLOGY TO MAXIMISE OPERATIONAL EFFICIENCY.

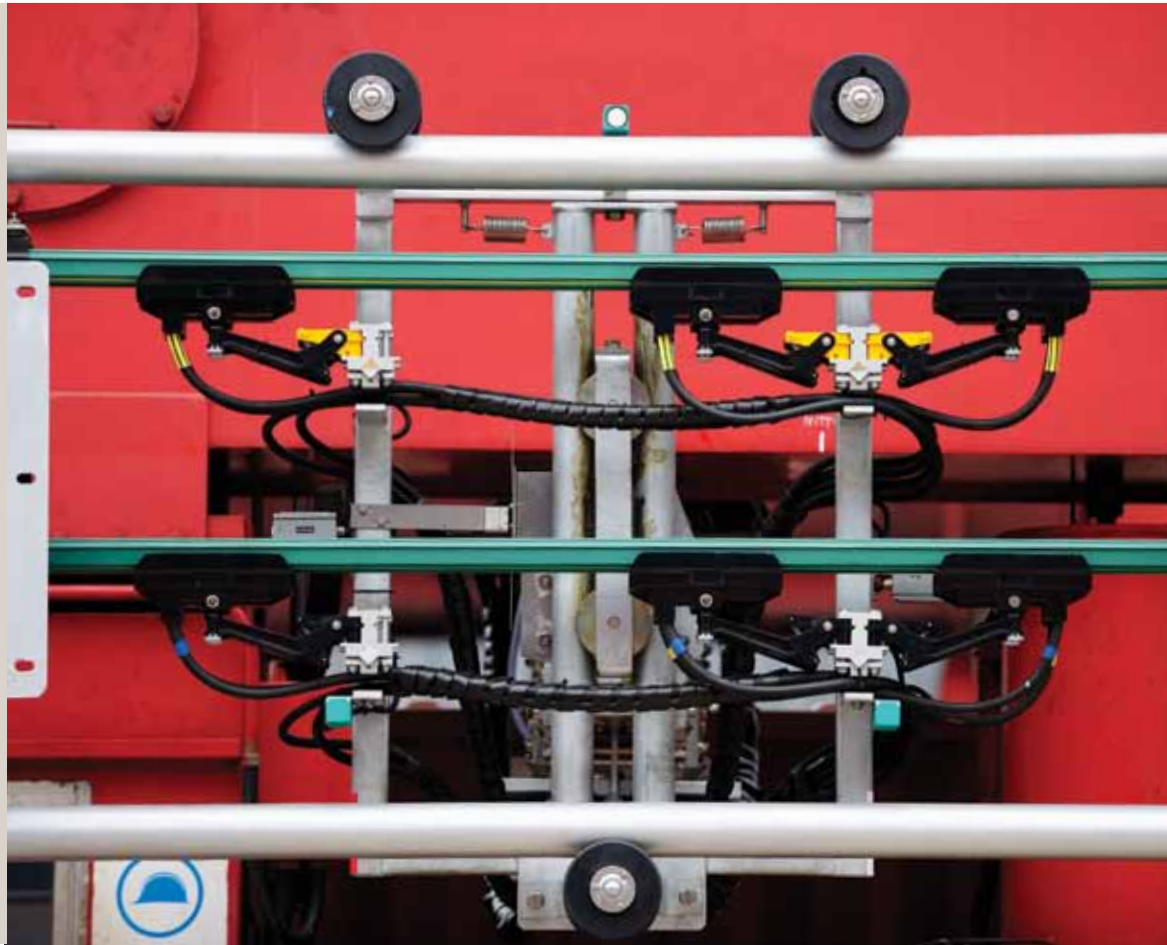

PLUG IN CONNECTION - AUTOMATIC CONNECTION WITH TELESCOPIC ARM

Electrifying RTGs can also be done with a conductor bar system. This solution allows for the RTG to be powered through conductor bars. A diesel generator is only required when maneuvering outside the aisle. There are currently two types of conductor rail systems available:

Manual solution with plug

- RTG moves with diesel generator stopping at the collector trolley
- Mechanical connection to the collector trolley established with steel ropes/coupling rod
- Manually disconnect of RTG generator
- Connect the plug hanging from the collector to The RTG
- RTG electrically powered in container aisle through the bus bar



Automatic solution with telescopic arm

- RTG moves with diesel generator stopping at the entrance point
- Collector trolley connects automatically to the bus bars
- RTG electrically powered in container aisle





ERTG COLLECTOR TROLRIES

- Manual system: collector trolley is permanently connected to the bus bars
- Automatic system: collector trolley is installed on the telescopic arm on board the ERTG

CONDUCTOR RAIL CONFIGURATION

As space conditions and requirements in container terminals are different, two types of conductor arrangements have been developed, these are:

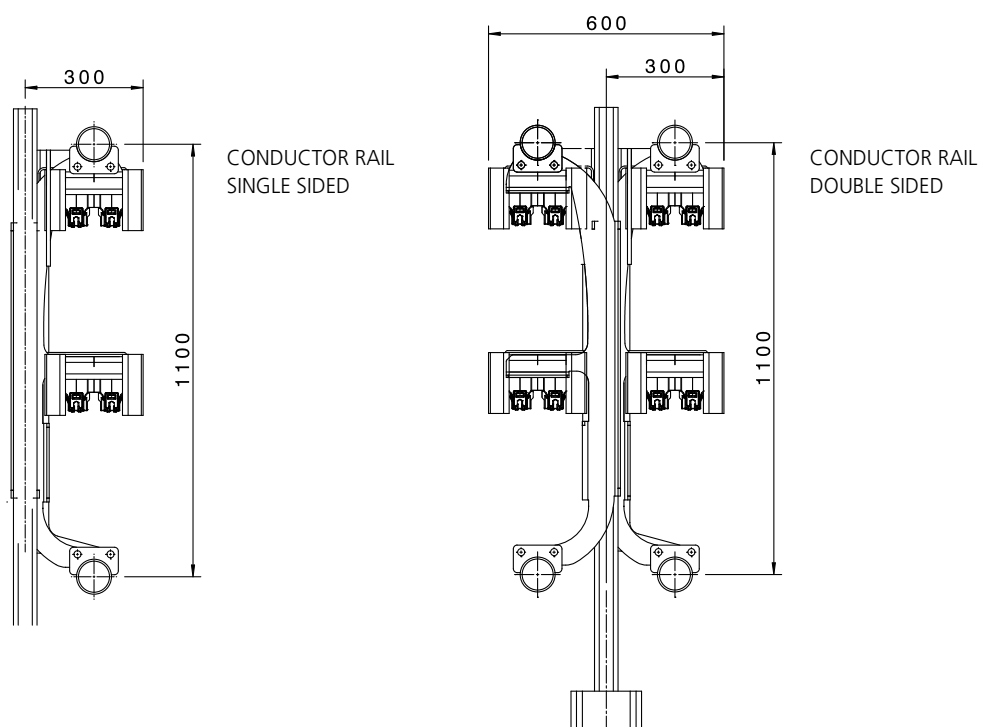

Installation & Maintenance

SERVICE IS A CRITICAL COMPONENT OF CAVOTEC'S. OUR LOCAL SALES AND SERVICE OFFICES, LOCATED AROUND THE WORLD, ARE BACKED BY THE EXPERTISE OF OUR CENTRES OF EXCELLENCE.



SERVICE & SUPPORT

Cavotec engineers provide unrivaled levels of customer service and support to ensure successful installation, commissioning and long service life.

We also provide on-site commissioning and training at our Centres of Excellence. Using in-depth manuals and system documentation, and our highly qualified engineers, we can provide all levels of training and maintenance instruction, in-line with your operational requirements.



Reference List

ACROSS INDUSTRIES, ACROSS THE WORLD; CAVOTEC DELIVERS ADVANCED TECHNOLOGIES DESIGNED TO HELP YOU IMPROVE OPERATIONAL EFFICIENCY AND INCREASE SUSTAINABILITY.



OUR PORT REFERENCES AROUND THE WORLD

ABB	Italia Marittima	Seawell
Aker Solutions	Kalmar	Siemens
Port of Antwerp	Koch	Port of Singapore
APL	Konecranes	Port of Shanghai
APM Terminals	Kuwait oil Co	Port of Shenzhen
BP	Port of Long Beach	StatoilHydro
British Royal Navy	Port of Los Angeles	Port of St Laurence
Port of Buenos Aires	MacGregor	Stora Enso
Port of Buzan	MAERSK Drilling	Port of St Petersburg
Port of Chennai	Maher Terminal	Port of Stockholm
China Shipping Lines	Port of Manzanillo	STX Shipyard
Contship/Eurokay	Matson Shipping	Sumimoto
Doosan Heavy Ind.	Port of Miami	Swedish Navy
DP World Cochin JNPT	Mitsubishi Heavy Industry	Techint
Port of Dubai	Mitsui	Port of Tianjin
Port of El Callao	MOL	TTS
Port of Everglades	MSC	U.S. Coast Guard
Evergreen	Port of Mumbai	U.S. Navy
Fantuzzi-Reggiane	National Oilwell	Port of Vancouver
Port of Felixstowe	Port of Ningbo	Port of Virginia
Fels crane	Noell	Yang Ming
FMC Technologies	NYK	ZPMC
Port of Gioia Tauro	Odin	
Port of Gothenburg	Port of Piraeus	
Port of Guangzhou	P.S.A.	
Port of Hamburg	Qatar Petroleum Co	
Port of Heidland	Port of Qingdao	
Port of Helsinki	Port of Rotterdam	
Port of Ho Ci Minh	Port of Salalah	
Port of Hong Kong	Samsung	
Hyundai Heavy Industry	Port of San Antonio	
Impsa	Port of Santos	



With a global presence of sales and manufacturing companies across six continents, Cavotec ensures each of our clients receives local, expert and personal service.

Cavotec's creativity and professionalism is founded on teamwork: working closely with clients, exchanging knowledge and ideas.



We are present in

Australia
Bahrain
Belgium
Brazil
Canada
Chile
China
Denmark
Finland

France
Germany
Greece
Hong Kong
India
Ireland
Italy
Lebanon
Luxemburg

The Netherlands
New Zealand
Norway
Peru
Qatar
Russia
Singapore
South Africa
South Korea

Spain
Sweden
Switzerland
U.A.E.
U.K.
U.S.A.

For more information please visit our website www.cavotec.com
or contact us directly at info@cavotec.com