

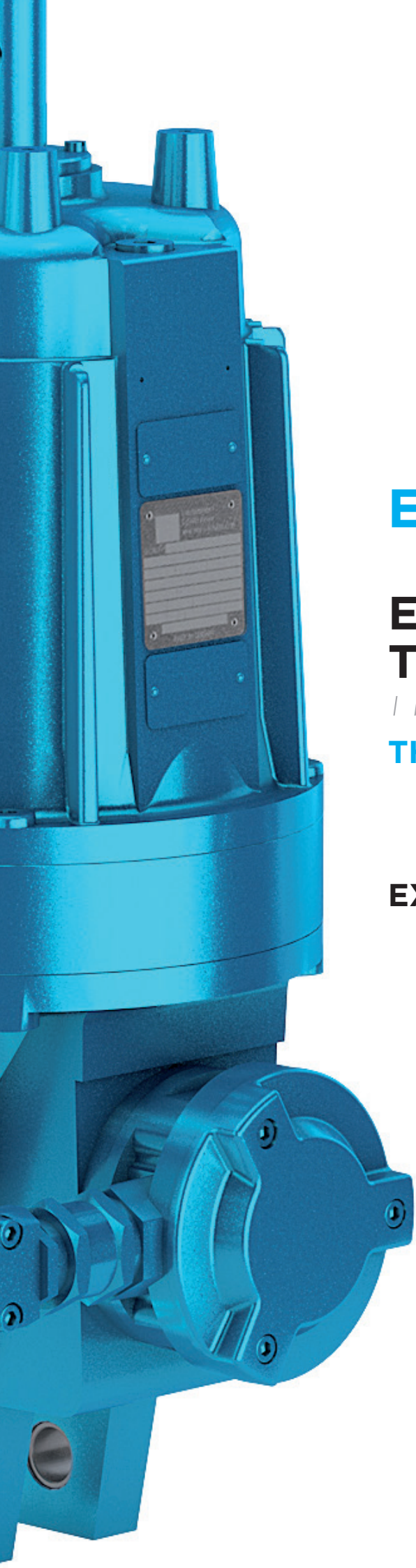

EMC



ELDRO®

**ELECTRO HYDRAULIC
THRUSTERS**



THE ORIGINAL. BE SAFE.

EXPLOSION-PROTECTED SERIES EDEX

EMC.moving ahead.

EXPLOSION-PROTECTED SERIES EDEX

AREAS OF APPLICATION

Gases, vapours, fumes and dust are generated or escape during the production, processing, transport and storage of combustible substances in many industrial sectors. When combined with oxygen, an explosive atmosphere can develop. If this ignites, it can result in explosions and cause serious personal injury and material damage. The sectors concerned include, for example, the chemical and petrochemical industries, pharmaceuticals, oil and gas production, mining, as well as the food industry, the biofuel industry and the wastewater sector.

Explosion-protected ELDRO® devices are ideal for these areas of application. They comply with current regulations and standards and can be used in a variety of ways.

TECHNICAL VALUES

Type	Lifting force [N]	Stroke path [mm]**	Power consumption [W]	Current consumption [A] at 400 V 50 Hz	Switching frequency with S3 operation [c/h]	Weight [kg]
EdEx 32/...	320	50	150	0.30	240	32
EdEx 50/...	500	60 - 160	180	0.38	240	32
EdEx 80/...	800	60 - 160	220	0.48	240	45 - 54*
EdEx 125/...	1250	60 - 160	250	0.52	240	45 - 54*
EdEx 150/...	1500	60 - 160	360	0.63	240	45 - 54*
EdEx 200/...	2500	60 - 160	320	0.64	240	71 - 80*
EdEx 250/...	2500	60 - 160	360	0.69	240	71 - 80*
EdEx 320/...	3200	100	550	0.9	240	75

* depending on stroke path

** further on request

Stroke work (N cm) = Lifting force x stroke path

EDEX

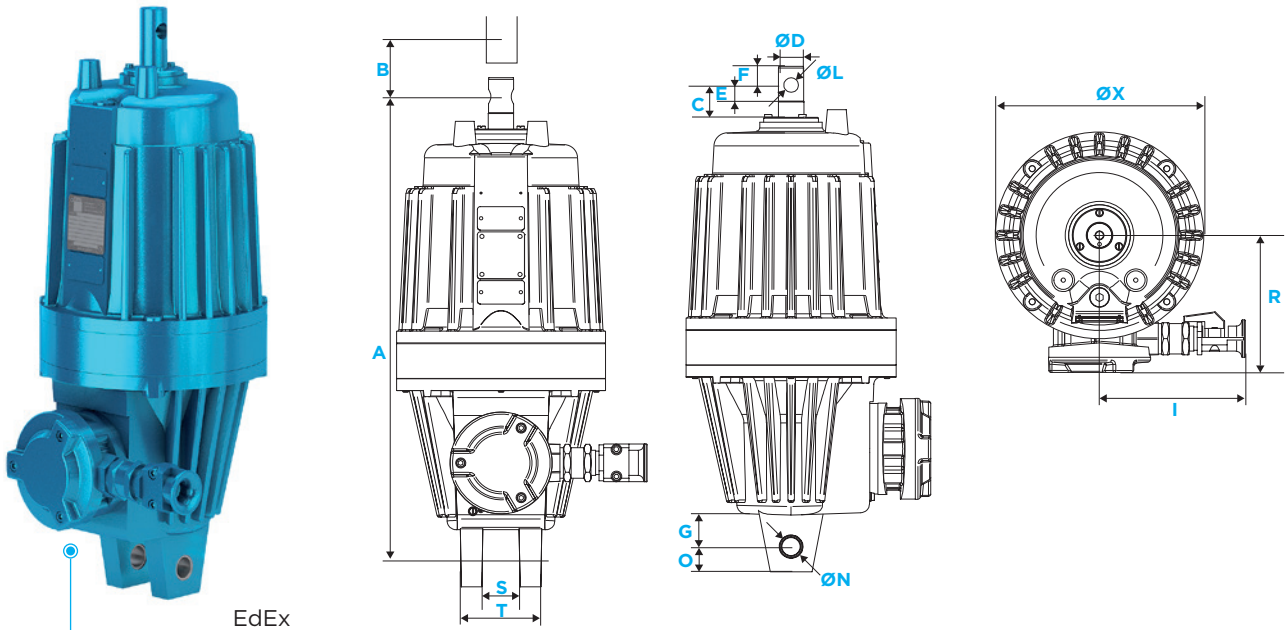

Type	A	B	C	ØD	E	F	G	I*	ØL	ØN	O	R	S	T	ØX
EdEx 32/50 EdEx 50/50	445	50	25	21,5	16	17	26	161	12	20	21	143	40	90	200
EdEx 80/60 EdEx 125/60 EdEx 150/60	514	60	30	27,5	18	21	35	161	16	20	28	153	40	90	230
EdEx 80/160 EdEx 125/160 EdEx 150/160	630	160	32	27,5	18	21	35	161	16	20	28	153	40	90	230
EdEx 200/60 EdEx 250/60	620	60	34	35,5	24	25	35	161	20	20	30	161	40	90	275
EdEx 200/160 EdEx 250/160	720	160	34	35,5	24	25	35	161	20	20	30	161	40	90	275

All dimensions in mm / * depending on cable gland

EDEX HV



EdEx HV

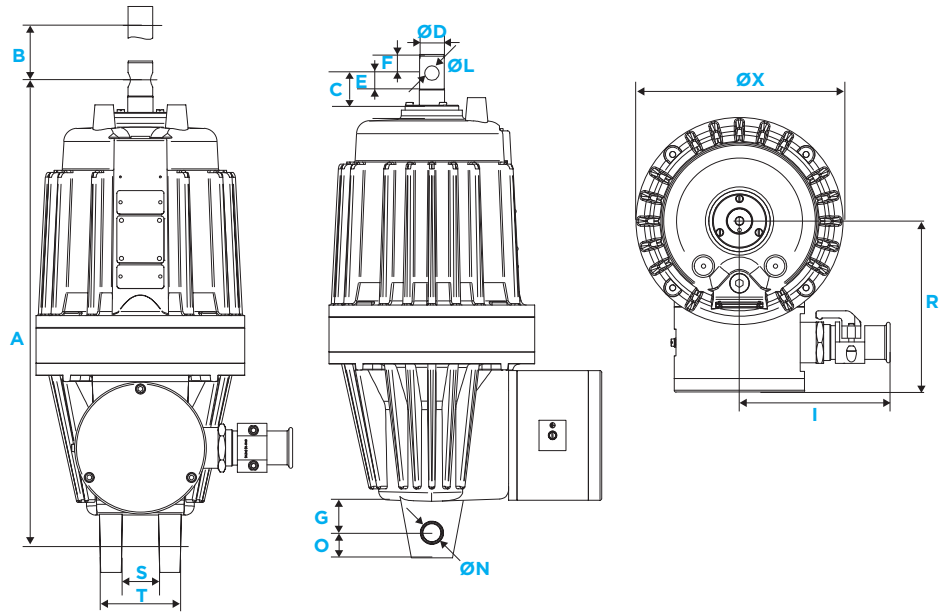

Type	A	B	C	ØD	E	F	G	I*	ØL	ØN	O	R	S	T	ØX
EdEx 80/60 EdEx 125/60 EdEx 150/60	514	60	30	27.5	18	21	35	168	16	20	28	190	40	90	230
EdEx 80/160 EdEx 125/160 EdEx 150/160	630	160	32	27.5	18	21	35	168	16	20	28	190	40	90	230
EdEx 200/60 EdEx 250/60	620	60	34	35.5	24	25	35	168	20	20	30	198	40	90	275
EdEx 200/160 EdEx 250/160	720	160	34	35.5	24	25	35	168	20	20	30	198	40	90	275

All dimensions in mm / * depending on cable gland

ELECTRICAL VERSION

MOTOR

- Three-phase asynchronous motor, 2-pole
- For power data see "Technical values"
- Standard insulation per insulation class F

VOLTAGES AND FREQUENCIES

- 400 V, 50 Hz, 3 -
- 500 V, 50 Hz, 3 -
- 690 V, 50 Hz, 3 -
- HV 660/1140 V, 50 Hz, 3 -
- All devices are star (Y) connected on delivery
- Special windings 110 V - 690 V, 3 -, 50 Hz and 60 Hz possible
- DC and AC versions are not available

CABLE INLET

- Threaded cable gland M 28 x 1.5 for cable cross-sections to 4 x 2.5 mm² (Ø 15 - 18 mm)
- HV device cable gland M 40 x 1.5 for cable cross-section to 7 x 2,5 mm² (Ø 18 - 21 mm)

OPERATING MODES

- Continuous operation S1 and intermittent duty S3 - 60 % duty cycle standard

TERMINAL BOX

- Protection class IP65, DIN VDE 0470 T1 (IEC 529)
- Supply line connection screw
- Internal protective conductor connection: Screw , HV device M5
- External protective conductor connection: M5

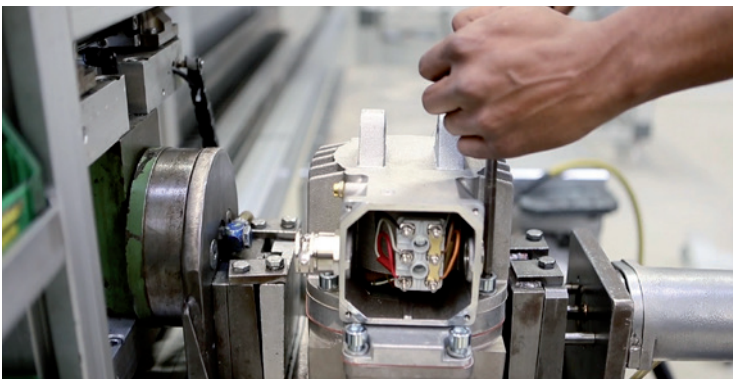

MECHANICAL VERSION

INSTALLATION VARIANTS

- The base fastening cannot be mounted in 90° rotated position
- The lifting rod head at the top rotates in all types

OPERATING FLUID

- Mineral hydraulic oil or silicone oil as well as aqueous polymer liquid depending on the operating conditions, e.g. ambient temperature, factory-filled

PAINT APPLICATION STANDARD

- 2K Polyacryl paint, layer thickness 120 µm
- Special paint layer thickness up to 200 µm
- Standard colour RAL 7022 (umbra grey)

PROTECTIVE MEASURES

- Simple dust protection seal
- Redundant seal with the hydraulic chamber
- Piston rod QPQ

ELECTRICAL & MECHANICAL AUXILIARY EQUIPMENT

LIFTING, LOWERING OR THROTTLING VALVE (H, S, D)

- With a built-in lift, lowering or throttling valve, lifting or lowering times as well as both times can be infinitely increased. The adjustable minimum values attain 10 to 20-times the normal values
- Integrated valves in “open position” result in an extension of the lifting and lowering times with short stroke thrusters of up to approx. 0.4 to 1.0 seconds, and with long stroke thrusters of up to approx. 0.7 to 2.0 seconds
- The desired lifting or lowering time is set externally on the device in standing position

CONTROL SPRING (R-SPRING)

- Damping of the load change when closing and opening the brake
- The R-spring is only effective in conjunction with a C-spring
- The installation length “A” of the device does not change
- When setting the working point of the brake, the spring characteristic must be taken into account
- Main application: ELDRO® control brake

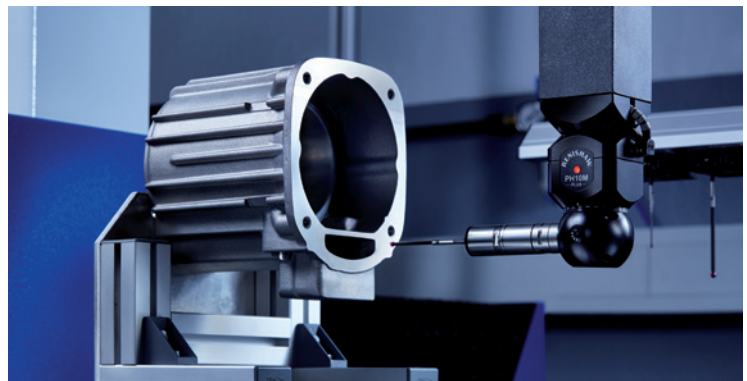

ELECTRICAL & MECHANICAL AUXILIARY EQUIPMENT

BRAKE SPRING (C-SPRING)

- Integrated c-spring for generating the brake force. The specified brake force of the C-spring is reached at 0...maximum of the nominal stroke

VERSIONS WITH BRAKE SPRING

Type	Brake spring force (c-spring) [N]
EdEx 32/50 C32	370 - 450
EdEx 50/50 C50	540 - 680
EdEx 80/60 C80	740 - 1060
EdEx 125/60 C125	1200 - 1630
EdEx 150/60 C125	1200 - 1630
EdEx 200/60 C200	1900 - 2500
EdEx 250/60 C200	1900 - 2500
EdEx 320/100 C320	2510 - 3690

INCREASED CORROSION PROTECTION

- Increased corrosion protection is necessary with the use of ELDRO® devices in environments of aggressive media and/or high relative humidity with the resultant formation of condensation
- Increased protection in the motor:**
The motor compartment is additionally coated with a corrosion protection
- Increased external protection:**
Through special paint application, see "Mechanical version"

LIMIT SWITCH (LI AND LM)

- For the electrical display of the ventilation and braking positions, mechanical or inductive limit switches can be installed on all ELDRO® units
- Detailed information available in the data sheet of the limit switches

REPLACEMENT DEVICES

- on request

CONFORMITY CERTIFICATE

- ATEX
- IEC Ex
- EAC



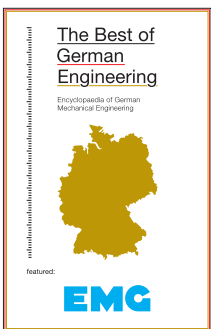

EMG Automation GmbH
Industriestraße 1 · 57482 Wenden, Germany
Phone: +49 27 62 6 12 - 0 · Fax: +49 27 62 6 12 - 320
www.emg-automation.com · eldro@emg-automation.com

eLEXIS Group